

NOTE:  
1.- USE 4043 WELD WIRE.  
2.- 6063 ASSEMBLY .375 WALL OR LESS TO BE HEAT-TREATED TO T6 TEMPER AFTER WELDING.

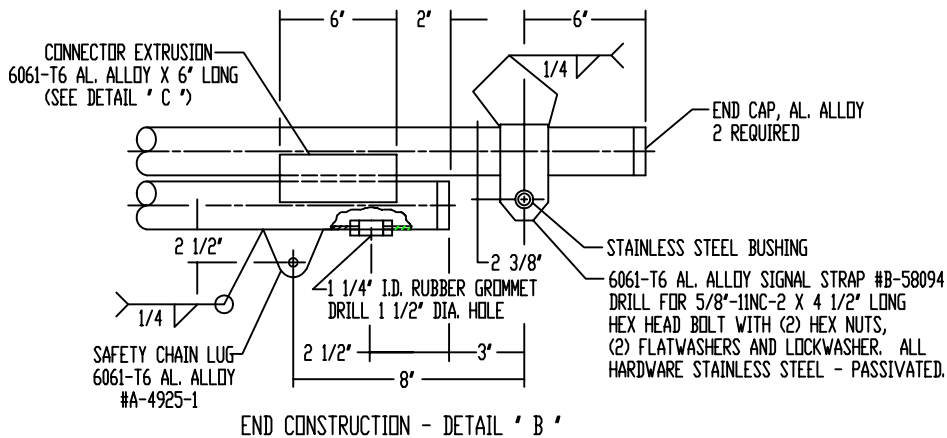
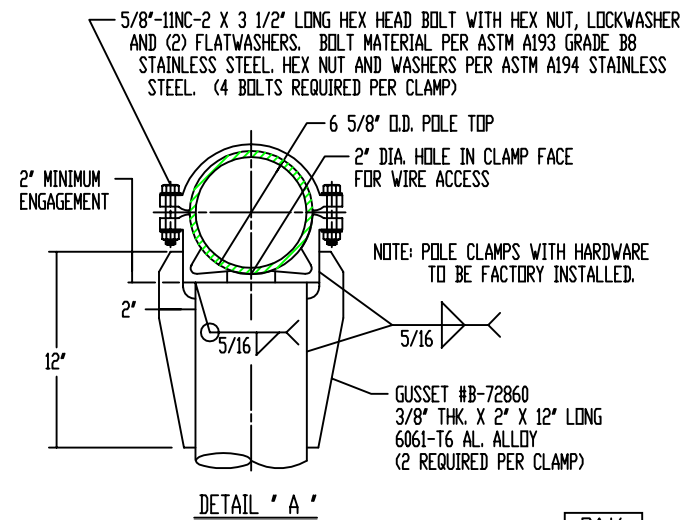
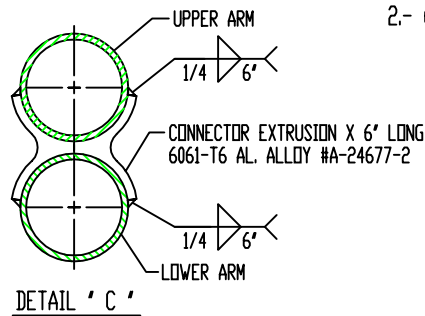

P&K

ALT.	DESCRIPTION	DATE	BY	CR	REVISION
					MATERIAL STOCK SIZE FINISH OR TEMPER QUANTITY CUSTOMER BERGEN COUNTY DEPT. OF PUBLIC WORKS
					P&K POLE PRODUCTS, INC. 84 Foundry St., Newark NJ TITLE BERGEN CODE " MA20-08 " MA2050566-70 DR. M.M.S. 05-12-95 CH. W.W.V. 05-12-95 SCALE NONE ING. NO. C-105469